

# DRINKING FOUNTAIN

STAINLESS STEEL - JUNIOR HEIGHT FLOOR STANDING

MODEL  
DF-972

# Gentworks



- Smooth rounded design
- 1.2mm thick grade 304 satin stainless steel
- Back to the wall or pedestal version available
- NSF approved bubbler tap
- Suitable for indoor or outdoor installation
- lockable door to access pipework.
- Adult height option available (DF-971)
- Ideal for schools and public amenities

This Junior height floor standing drinking fountain features an undershroud with lockable door to conceal pipework. The fountain is fixed to the floor at the base making it more resistant to vandalism. As standard, the back and base of the fountain is open to allow water waste pipe connections to enter from below or from the wall behind.

A closed back option is available so the unit can be installed as a free standing pedestal with supply pipe and waste pipe connections made from below.

The drinking fountain is supplied with a chrome plated shielded bubbler with self closing push button valve, water inlet fitting to suit 15 mm diameter pipework and 32 mm (1¼ in) BSP unslotted grated waste fitting.

This stainless steel drinking fountain is suitable for outside installation but will need to be isolated and drained down during periods of freezing weather to prevent damage to the valve and pipework.

Supplied with a 32mm grated waste fitting and a chrome plated brass shielded bubbler complete with water inlet fitting to suit 15mm diameter pipework.

## Sample specification Text

Stainless steel Floor Standing Junior Height Drinking Fountain - 310mm (W) x 310mm (D) x 760mm (H) with **Open Back** for Back to the wall installation or **Closed Back** for Pedestal installation. Supplied complete with 32mm waste and push button bubbler tap - Product Code GW-972

\***RED TEXT** may denote a variable

# DRINKING FOUNTAIN

STAINLESS STEEL - JUNIOR HEIGHT FLOOR STANDING

MODEL  
DF-972

# Gentworks

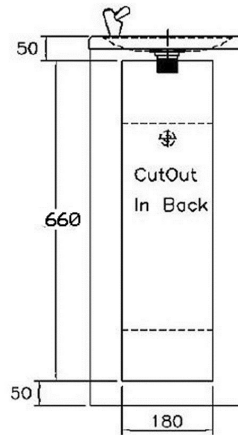
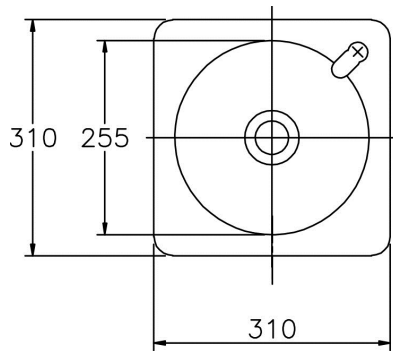

Rear View  
(Open Back Junior Version)

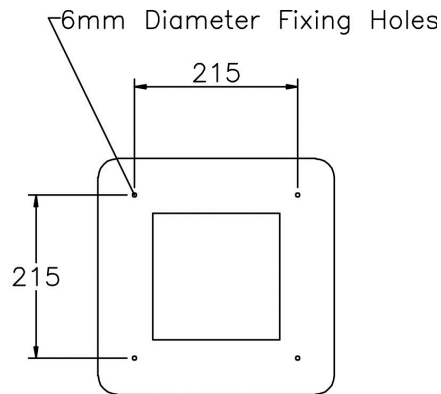
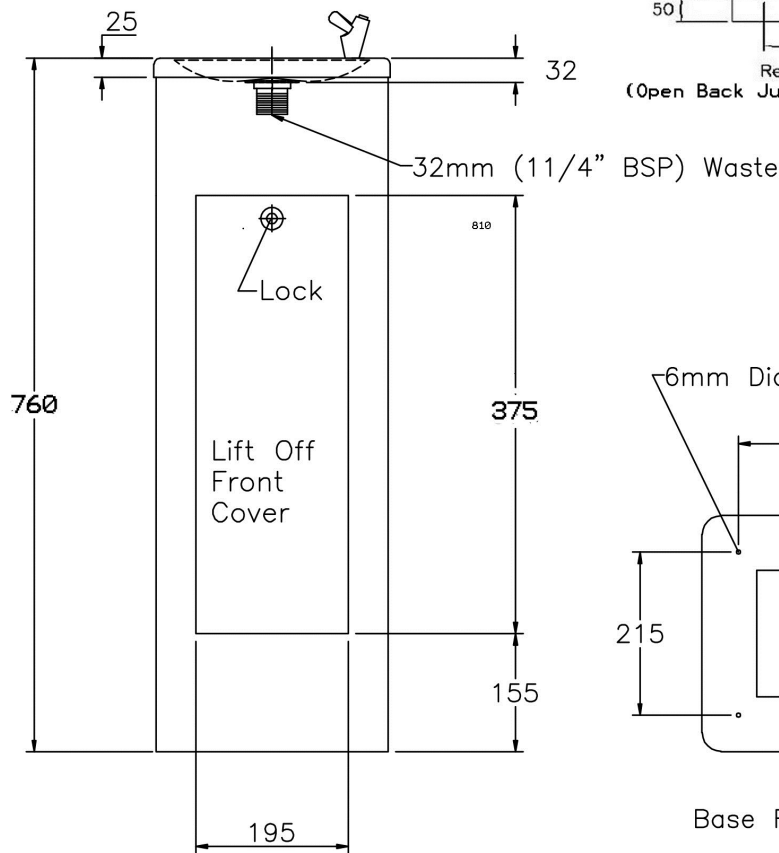

Base Fixing Details

## Dispenser Options Specify when ordering



**Heavy Duty Bubbler Valve:** NSF shielded chrome press button drinking water bubbler valve (tap) with easily replaceable self-contained **Pro-Flo™** cartridge.



**Bottle / Cup Filler:** self-closing push button valve fitted with a 255mm high, chrome plated, fixed brass swan-neck spout. Water only flows whilst the button is depressed. This dispenser is not suitable for areas vulnerable to vandalism.

